



US 20110076089A1

(19) **United States**

(12) **Patent Application Publication**  
**Geminiani**

(10) **Pub. No.: US 2011/0076089 A1**

(43) **Pub. Date: Mar. 31, 2011**

(54) **IMPROVED FOUNTAIN PEN**

**Publication Classification**

(75) Inventor: **Marco Geminiani**, Bologna (IT)

(51) **Int. Cl.**  
**B43K 5/06** (2006.01)  
**B43K 5/04** (2006.01)

(73) Assignee: **Gian Luca Malaguti**, Bologna (IT)

(21) Appl. No.: **12/993,448**

(52) **U.S. Cl.** ..... **401/176; 401/245**

(22) PCT Filed: **May 7, 2009**

(57) **ABSTRACT**

(86) PCT No.: **PCT/IB2009/051884**

§ 371 (c)(1),  
(2), (4) Date: **Nov. 18, 2010**

An improved fountain pen (1) comprises a hollow barrel (2) with a longitudinal central axis of extension (X), a nib (3) located at a first longitudinal end (2a) of the barrel (2), an ink reservoir (4) located inside the barrel (2) and designed to feed the ink to the nib (3), a piston (5) able to move axially along the central axis (X) to create a vacuum inside the ink reservoir (4); the ink reservoir (4) also comprising a sac (6) made of deformable material.

(30) **Foreign Application Priority Data**

May 20, 2008 (IT) ..... BO2008A000311  
Jun. 9, 2008 (IT) ..... BO2008A000362

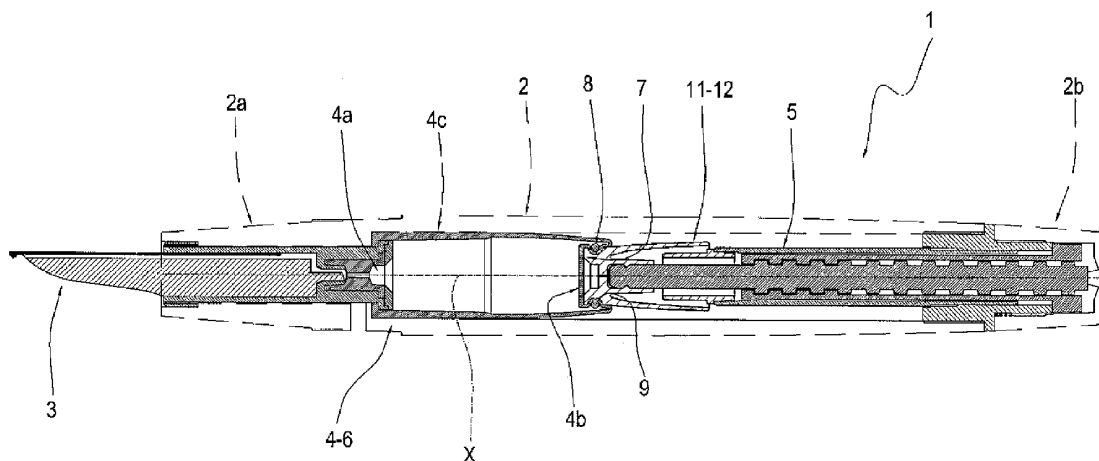

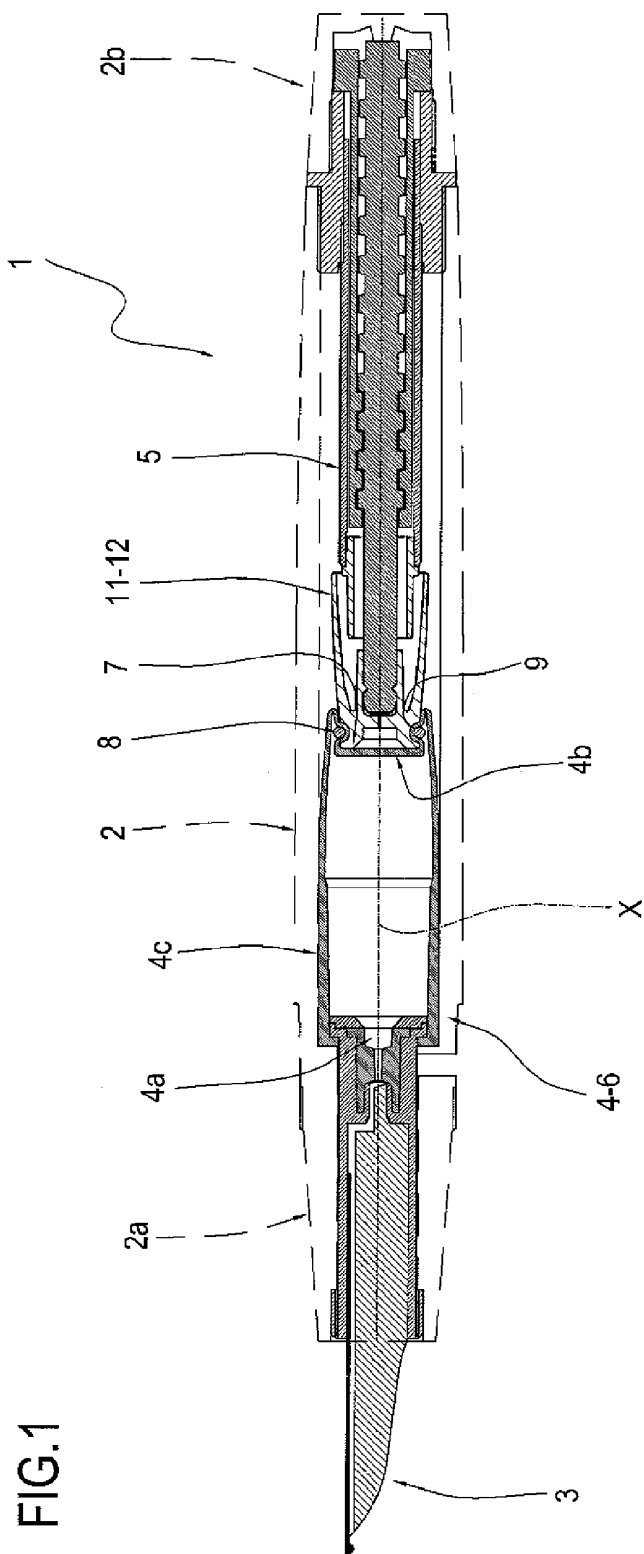

FIG.2

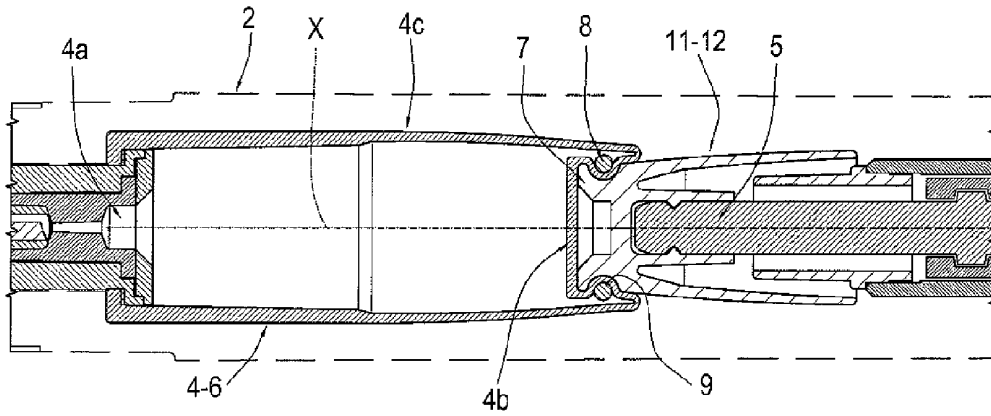

FIG.3

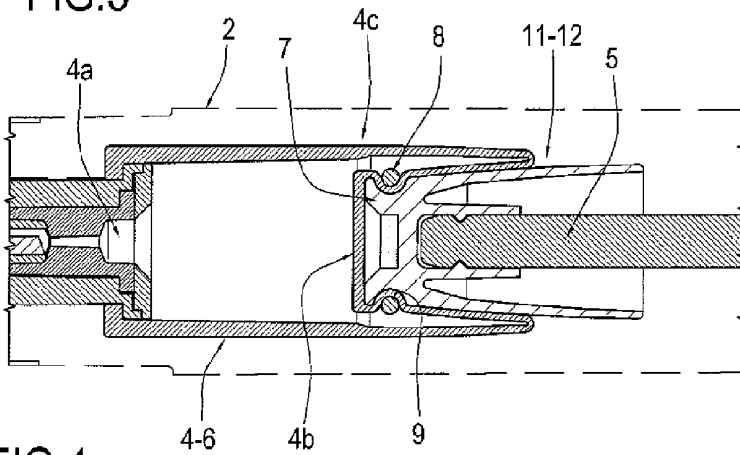

FIG.4

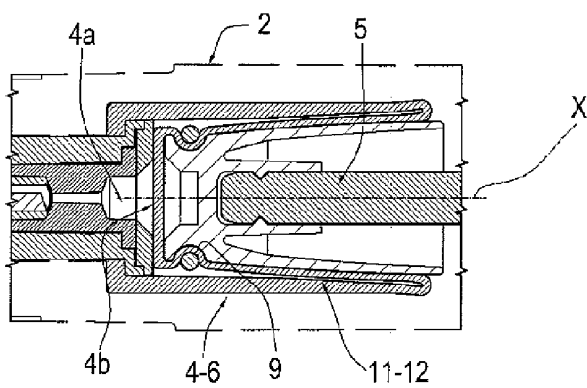

FIG.5

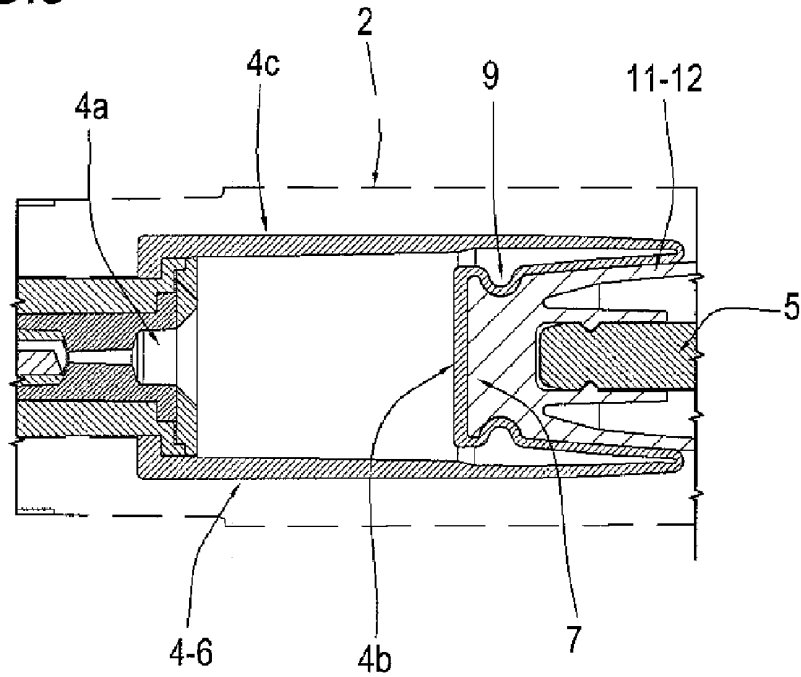
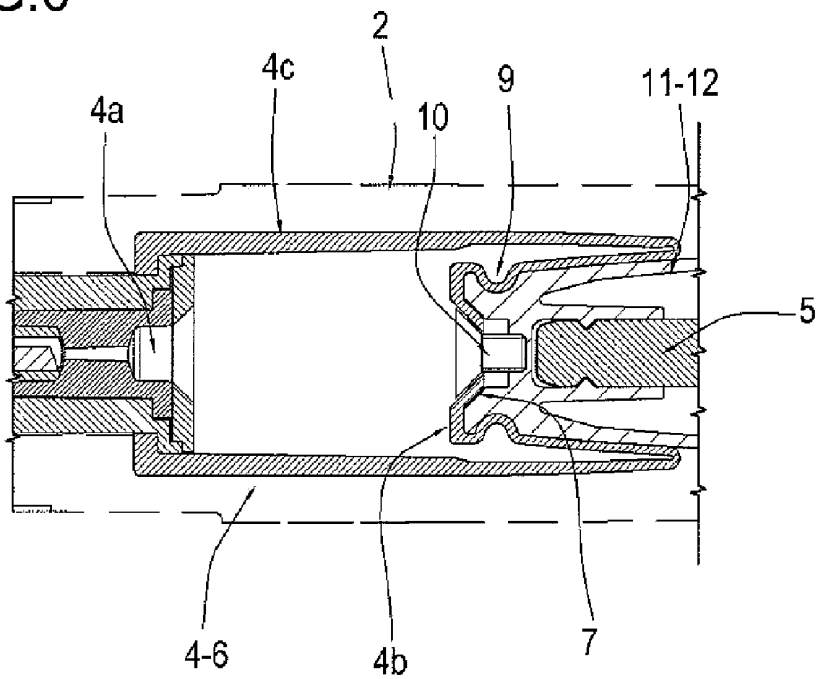
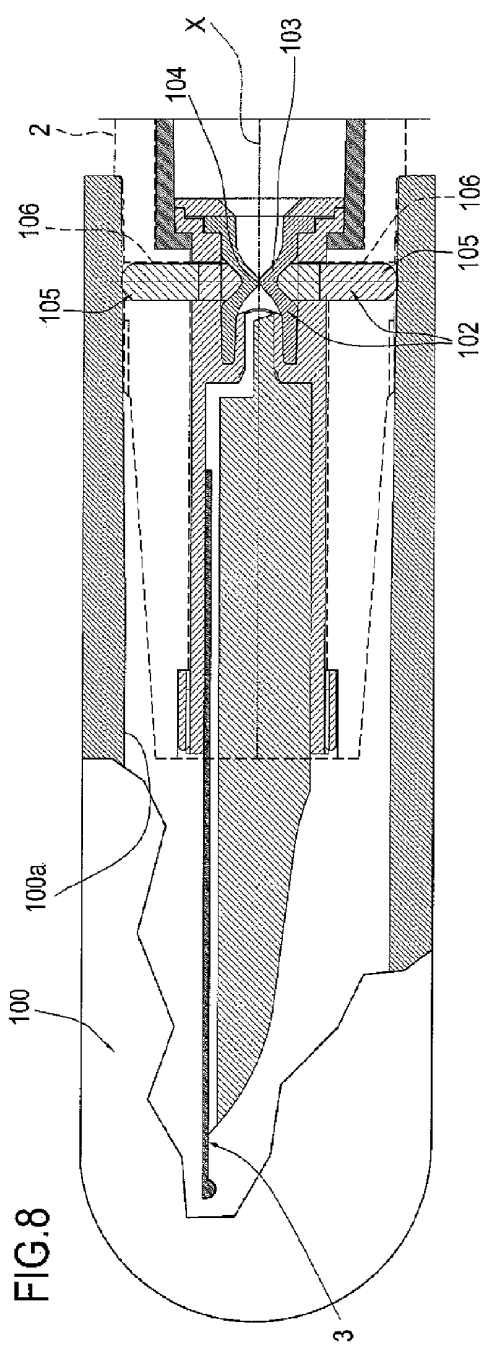
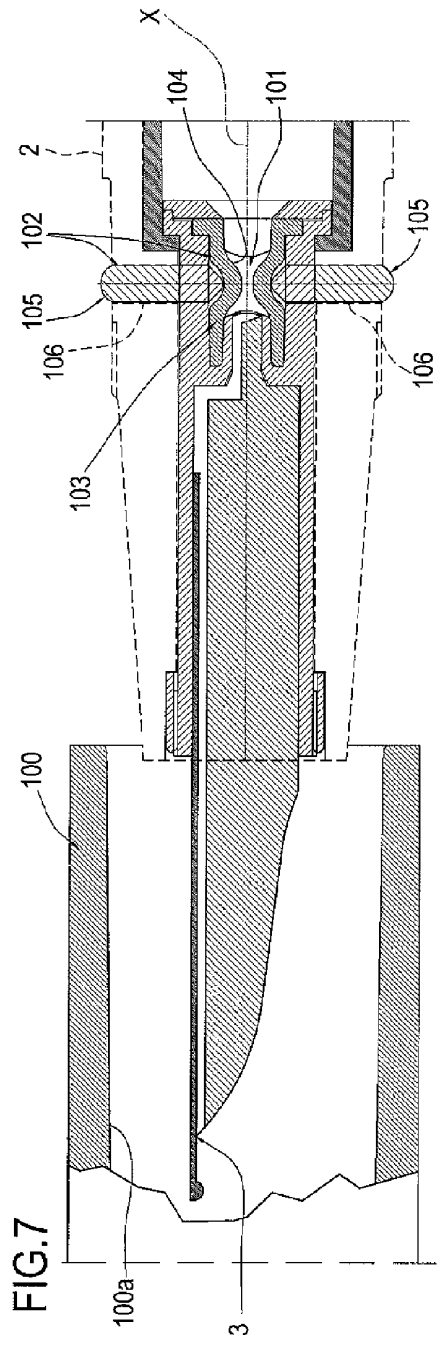

FIG.6





## IMPROVED FOUNTAIN PEN

### TECHNICAL FIELD

[0001] The present invention relates to an improved fountain pen.

[0002] In particular, the present invention relates to a fountain pen of the type with a refillable ink reservoir.

### BACKGROUND ART

[0003] There are many prior art solutions and methods for filling the ink reservoir with ink.

[0004] Amongst the various systems commonly used, with the passage of time the use of vacuum filling became established, due to its practicality and effectiveness.

[0005] The system involves filling by creating a vacuum inside the pen body so that the ink is sucked in by it.

[0006] The most used method involves syringe filling, which uses the more classic method for creating a vacuum: that of moving a plunger backwards in a cylindrical hollow body, precisely as occurs for syringes.

[0007] That system is simple to make from a mechanical viewpoint and is usually made with a shaft inserted through a hole in the end part of the pen.

[0008] At the other end of the shaft, inserted in the pen body, a seal is mounted.

[0009] Filling is performed by accessing the shaft from the rear of the pen and pushing it as far as it will go, then sucking in the ink, exactly as occurs with a syringe, by pulling the shaft backwards.

[0010] The most used mechanism for the movement of the shaft/plunger is of the male and female screw type.

[0011] Turning the end part of the pen (the bottom) makes the shaft/plunger move forwards or backwards and causes consequent emptying/filling of the ink from/to the inside of the ink reservoir.

[0012] Like any cylinder—piston type connection, prolonged use compromises the seal between the two components, causing unwanted ink leaks, with the obvious risk that ink may get out of the ink reservoir.

[0013] Moreover, fountain pens comprise a nib in fluid communication with the ink reservoir through a channel which allows the ink to pass from the ink reservoir to the nib.

[0014] Some such pens also comprise a nib closing cap which is applied to the end of the barrel after the pen has been used.

[0015] Ink is often leaked from the channel connecting the ink reservoir to the nib, even when the pen is not used and the cap is applied to the barrel.

[0016] Such leaks are more frequent if the pen is in environments in which the temperature or the pressure vary, for example during aeroplane flights.

[0017] Leaks cause unwanted marks on clothing (for example, a shirt or jacket pocket) or the containers where the pen is put away.

### DISCLOSURE OF THE INVENTION

[0018] The present invention has for an aim to provide an improved fountain pen which is free of the disadvantages described above and which at the same time has a simple structure, is practical to use and operates effectively.

[0019] In particular, the present invention has for an aim to provide a fountain pen equipped with components which guarantee an effective ink seal.

[0020] The technical features of the present invention, in accordance with the above aim, are clear from the content of the claims herein, in particular claim 1 and, preferably, from any of the claims directly or indirectly dependent on claim 1.

### BRIEF DESCRIPTION OF THE DRAWINGS

[0021] The advantages of the present invention are more apparent in the detailed description which follows, with reference to the accompanying drawings which illustrate a preferred, non-limiting embodiment of the invention, in which:

[0022] FIG. 1 is a schematic cross-section of a preferred embodiment of the fountain pen according to the present invention;

[0023] FIG. 2 is a schematic cross-section of a detail of the pen of FIG. 1 in a first operating configuration;

[0024] FIG. 3 is a schematic cross-section of the detail of FIG. 2 in a second operating configuration;

[0025] FIG. 4 is a schematic cross-section of the detail of FIG. 2 in a third operating configuration;

[0026] FIG. 5 illustrates a second, alternative embodiment of the detail of FIGS. 2, 3 and 4;

[0027] FIG. 6 illustrates a third, alternative embodiment of the detail of FIGS. 2, 3 and 4;

[0028] FIG. 7 is a schematic cross-section, with some parts cut away to better illustrate others, of a detail of the pen according to a fourth, alternative embodiment, in a first operating position;

[0029] FIG. 8 is a schematic cross-section, with some parts cut away to better illustrate others, of a detail of the pen according to a fourth, alternative embodiment, in a second operating position.

### DETAILED DESCRIPTION OF THE PREFERRED EMBODIMENTS OF THE INVENTION

[0030] With reference to the accompanying drawings and in particular to FIG. 1, the numeral 1 denotes as a whole a fountain pen made according to the present invention.

[0031] The pen 1 comprises a substantially cylindrical hollow barrel 2, forming the outer casing of the pen 1 and intended to be gripped by the user during normal use of the pen.

[0032] The pen 1 has a longitudinal central axis of extension X. The hollow barrel 2 extends along said longitudinal axis X and comprises two ends, a first end 2a and a second end 2b.

[0033] A nib 3, usually made of metal material, is connected to the first end 2a of the barrel 2.

[0034] Inside the barrel 2 there is an ink reservoir 4, designed to feed ink to the nib 3, and a piston 5, able to move axially inside the barrel 2 to create a vacuum inside the ink reservoir 4 by compressing/decompressing the ink reservoir 4 with its axial movement.

[0035] The mechanism used for the axial movement of the piston 5 is of the known type (a male-and-female screw coupling) and therefore is not described in further detail.

[0036] The ink reservoir 4 comprises a sac 6 made of deformable material such as silicone and extends inside the barrel 2, along the longitudinal central axis of extension X.

[0037] As FIGS. 1 and 2 show, the shape of the ink reservoir 4 is at least roughly cylindrical and it has two opposite longitudinal ends, a first end 4a and a second end 4b as well as a cylindrical lateral wall 4c.

[0038] The first end **4a** is open, so that the ink reservoir **4** is in fluid communication with the nib **3**, allowing the ink to flow towards the nib **3**.

[0039] The second end **4b** of the ink reservoir **4** is closed and is connected to the end part **7** of the piston **5**.

[0040] In more detail, in the embodiment illustrated in FIGS. **1**, **2**, **3** and **4** the second end **4b** of the ink reservoir **4** is fixed to the end part **7** of the piston **5** by a circumferential ring **8** inserted in a respective groove **9** made in the end part **7** of the piston.

[0041] The second end **4b** of the ink reservoir **4** remains interposed between the circumferential ring **8** and the groove **9**.

[0042] FIG. **5** shows an alternative embodiment of the pen in FIGS. **1** to **4**, in which the second end **4b** of the ink reservoir **4** is connected to the end part **7** of the piston **5** by gluing.

[0043] In FIG. **6**, according to another alternative embodiment of the present invention, the second end **4b** of the ink reservoir **4** is fixed to the end part **7** of the piston **5** by a screw **10** passing through the second end **4b** of the ink reservoir **4** and which engages by screwing in the end part **7**.

[0044] In practice, as shown in detail in FIGS. **2**, **3** and **4**, the ink reservoir **4** is deformable between a first limit position with maximum internal volume, in which the two ends **4a**, **4b** of the ink reservoir **4** are distanced from each other, and a second position with reduced internal volume, in which the first end **4a** and the second end **4b** of the ink reservoir **4** are close together.

[0045] In practice, the cylindrical lateral wall **4c** of the ink reservoir **4**, pushed by the piston **5**, folds inwards in such a way that portions of the wall **4c** overlap each other, maintaining a cylindrical shape.

[0046] The piston **5** comprises an element **11** which acts as a guide and maintains the shape of the ink reservoir **4**.

[0047] The guide element **11** comprises a cylindrical block **12** with a diameter which is smaller than the diameter of the ink reservoir **4**.

[0048] In more detail, the diameter of the guide element **11** is slightly smaller than the diameter of the ink reservoir **4**, so that when the cylindrical lateral wall **4c** of the ink reservoir **4** folds inwards, the guide element **11** keeps the inner portion of lateral wall **4c** drawn near to the corresponding outer portion of cylindrical lateral wall **4c**, as FIG. **4** clearly shows.

[0049] Moreover, as shown in the accompanying drawings, the thickness of the cylindrical lateral wall **4c** of the ink reservoir **4** varies along the axis X, facilitating inward folding of the lateral wall **4c**.

[0050] According to an alternative embodiment not illustrated, the cylindrical lateral wall has at least one circumferential preferred folding line.

[0051] FIGS. **7** and **8** show another possible alternative embodiment of the fountain pen according to the present invention.

[0052] According to that alternative embodiment, the pen **1** also comprises a cap **100** for covering the nib **3**. The cap can be applied to the first end **2a** of the barrel **2**.

[0053] The cap **100** is applied to the barrel **2** when the pen **1** is not being used.

[0054] The nib **3** is in fluid communication with the ink reservoir **4** by means of a channel **101** through which ink flows from the ink reservoir **4** to the nib **3**.

[0055] As illustrated in FIGS. **7** and **8**, the pen comprises valve means **102** for closing the channel **101**.

[0056] The valve means **102** comprise a substantially cylindrical body **103** which is hollow inside and elastically deformable.

[0057] The cylindrical body **103** is made of silicone material and has an inner wall **104**.

[0058] The cylindrical body **103** can move between an open position, illustrated in FIG. **7**, in which the channel **101** for the passage of the ink is open, and a closed position, illustrated in FIG. **8**, in which the channel **101** is closed.

[0059] Advantageously, as shown in FIGS. **7** and **8**, the inner wall of the cylindrical body **103** forms a wedge shape towards the axis X, in such a way that in the closed position the surfaces of the cylindrical body **103** which make contact to close the channel **101** are limited to the vertex of the wedge: in that way the seal is significantly increased.

[0060] The valve means **102** also comprise a pair of cylindrical body **103** actuator pins **105**, inserted in respective cavities **106** made in the barrel **2** and able to move in a direction transversal to the direction identified by the axis X.

[0061] The pins **105** move, inside the cavities **106**, between a raised position corresponding to the cylindrical body **103** open position (illustrated in FIG. **7**) and a lowered position in which they move the cylindrical body **103** to the closed position (illustrated in FIG. **8**).

[0062] When the pen **1** is in the operating condition, the pins **105** are in the raised position, allowing the passage of ink.

[0063] As shown in FIG. **8**, when the cap **100** is applied to the barrel **2**, when the user has finished using the pen **1**, the inner wall **100a** of the cap **100** pushes the pins **105** into the lowered position, the pins **105**, in turn, moving the cylindrical body **103** into the closed position.

[0064] In this way, when the cap **100** is put on, the possibility of ink passing from the channel **101** towards the nib **3** is automatically eliminated, because the channel **101** is closed.

[0065] Similarly, when the cap **100** is removed, the cylindrical body **103** elastically deforms and again moves the pins **105** to the open position. The channel **101** opens again and ink flows towards the nib **3**.

[0066] The pen **1** also comprises locking means for the pins **105** which prevent the pins **105** from slipping out of their cavities **106**.

[0067] The locking means comprise a stop element designed to prevent the pin **105** from sliding beyond the open position towards the outside of the cavity **106**.

[0068] The present invention brings important advantages.

[0069] The piston always remains outside the ink reservoir and does not act directly on the ink, instead acting on the ink reservoir, which, as already indicated, deforms by folding inwards.

[0070] In that way, the top of the ink reservoir forms a closed chamber absolutely preventing the possibility of any ink leaks outside the ink reservoir.

[0071] The ink can only flow out towards the nib from the open end of the ink reservoir, but cannot flow out of the top, thanks to the fact that the ink reservoir is closed and the piston acts on the ink reservoir from the outside.

[0072] Moreover, the valve means prevent ink leaks each time the cap is applied to the barrel, thus preventing unwanted marks on clothing or in the containers where the pen is put away.

[0073] The ink can only flow out towards the nib from the open end of the ink reservoir, said end being closed by the valve means when the cap is applied to the barrel.

1-13. (canceled)

14) An improved fountain pen comprising:

a hollow barrel (2) with a longitudinal central axis of extension (X);

a nib (3) located at a first longitudinal end (2a) of the barrel (2);

an ink reservoir (4) located inside the barrel (2) and designed to feed the ink to the nib (3);

a piston (5) able to move axially along the central axis (X) to create a vacuum inside the ink reservoir (4), the fountain pen being characterised in that the ink reservoir (4) comprises a sac (6), the fountain pen being characterised in that it comprises:

a channel (101) connecting the nib (3) to the ink reservoir (4);

valve means (102) for closing the channel (101);

a cap (100) for covering the nib (3) and which can be applied to the barrel (2) at the first end (2a), the cap interacting with the valve means (102);

the valve means (102) comprising an elastically deformable cylindrical body (103) surrounding the channel (101), being able to move between an open position, in which the channel (101) for the passage of the ink is open when the pen is in use, and a closed position, in which the channel (101) is closed when the cap (100) is applied on the barrel (2) covering the nib (3).

15) The fountain pen according to claim 14, characterised in that the inner wall of the cylindrical body (103) forms a wedge shape towards the axis (X), in such a way that in the closed position the surfaces of the cylindrical body (103) which make contact to close the channel (101) are limited to the vertex of the wedge.

16) The fountain pen according to claim 14, characterised in that the valve means (102) can move between a first, open position, in which the channel (101) is open, and a closed position, in which the channel (101) is closed, the valve means (102) moving to the closed position when the cap (100) is applied to the barrel (2).

17) The fountain pen according to claim 16, characterised in that it comprises a pair of pins (105) designed to move the cylindrical body (103) from the open position to the closed position.

18) The fountain pen according to claim 17, characterised in that the pins (105) are operated by the cap (100), when the cap (100) is applied to the first end (2a) of the barrel (2).

19) The fountain pen according to claim 14, characterized in that the ink reservoir (4) is made of silicon material, extends along the central axis (X) and has two opposite longitudinal ends (4a, 4b), one of the ends (4a) being open to put the ink reservoir (4) in communication with the nib (3), via the valve means (102), and that the ink reservoir (4) is deformable at least between a first limit position with maximum internal volume, in which the ends (4a, 4b) of the ink reservoir (4) are distanced from each other, and a second position with reduced internal volume, in which the ends (4a, 4b) of the ink reservoir (4) are close together.

20) The fountain pen according to claim 14, characterised in that the ink reservoir (4) comprises a cylindrical wall (4c) whose thickness varies along the axis (X).

21) The fountain pen according to claim 14, characterised in that the ink reservoir (4) comprises a cylindrical wall (4c) with at least one circumferential preferred folding line.

22) The fountain pen according to claim 14, characterised in that the piston (5) comprises an element (11) which acts as a guide and maintains the shape of the ink reservoir (4) during the passage between the first and second position and vice versa.

23) The fountain pen according to claim 14, characterised in that the piston (5) is connected to a mobile end (4b) of the ink reservoir (4).

24) The fountain pen according to claim 14, characterised in that the piston (5) is connected to a mobile end (4b) of the ink reservoir (4) by a circumferential ring (8) housed in a groove made in the end of the piston.

25) The fountain pen according to claim 14, characterised in that the piston (5) is connected to a mobile end (4b) of the ink reservoir (4) by gluing.

\* \* \* \* \*